

PUMP

BEST ONE MA
BEST ONE VOX MA

BEST ONE MS

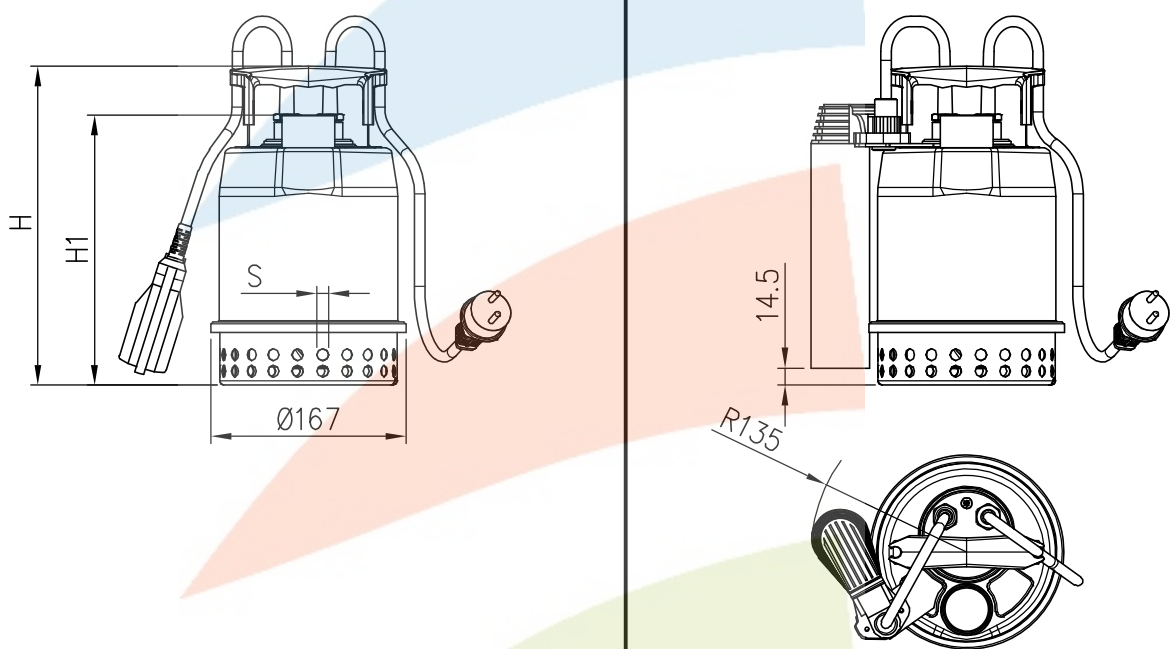

Pump Type	Dimensions [mm]			Weight [kgf]
	H	H1	S	
BEST ONE	273	231	10	4,3
BEST ONE M				4,4
BEST ONE MA				4,6
BEST ONE MS				4,8
BEST ONE VOX	304	262	20	4,4
BEST ONE VOX M				4,5
BEST ONE VOX MA				4,7