

PUMP 3(.)M 32, 40, 50, 65-125/160

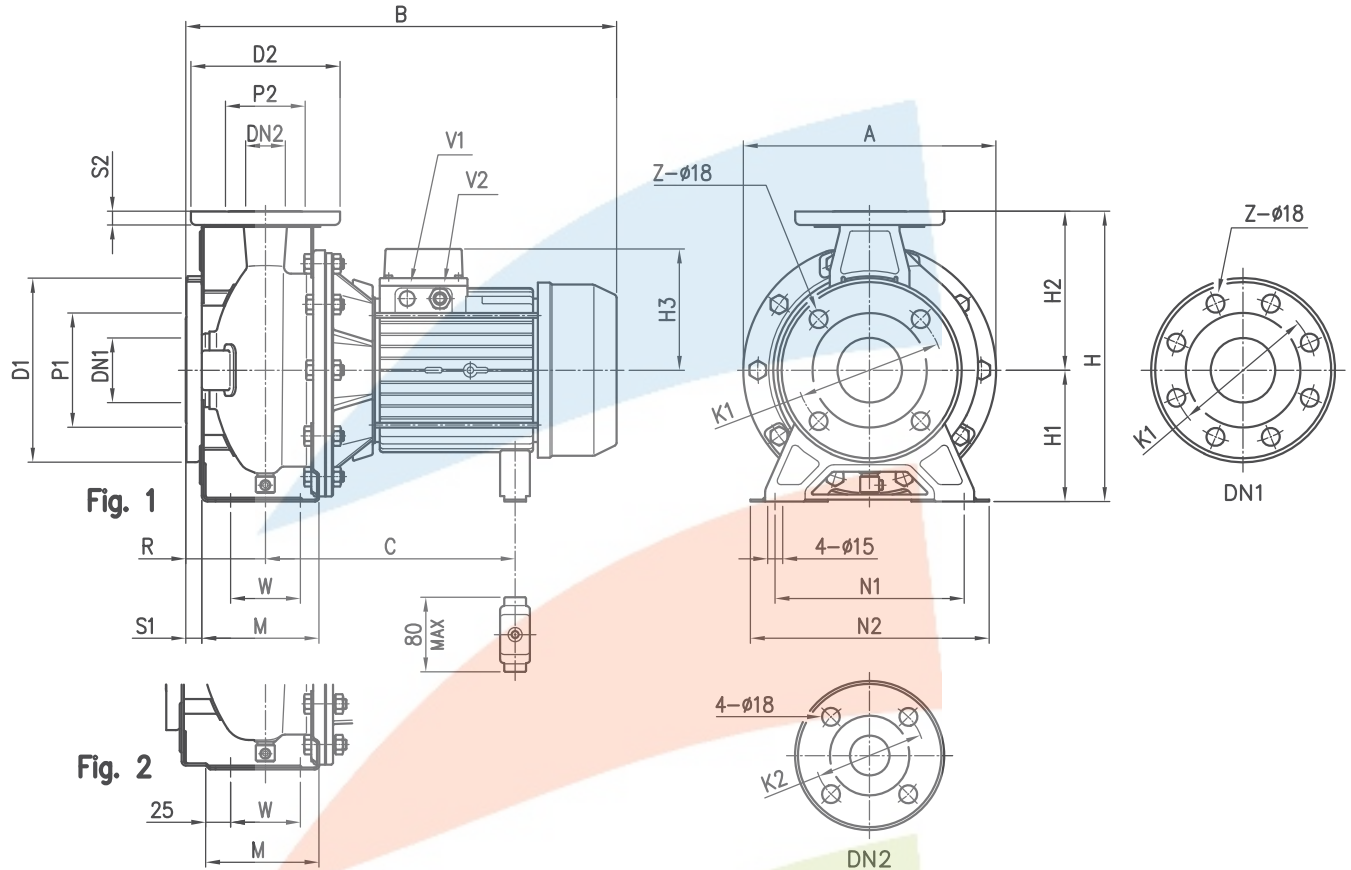

Model	Dimensions (mm)																			Weight [kgf]															
	DN1	P1	K1	D1	S1	[1]	[2]	DN2	F2	K2	D2	S2	Fig.	H	H1	H2	[3-]	[1-]	R	W	M	N1	N2	A	[1-]	[3-]	(*)	[1-]	[3-]	V1	[3-]	[1-]	[3-]	(*)	[3-]
32-125/1.5 (M)	50	95	125	165	16	4	-	32	75	100	140	14	1	252	112	140	124	141	80	70	114	140	190	213	408	407	-	219+230	219+230	-	PG 13.5	M20x1.5	19,6	24,1	-
32-160/1.5 (M)	50	95	125	165	16	4	-	32	75	100	140	14	1	292	132	160	124	141	80	70	118	190	240	254	408	407	-	219+230	219+230	-	PG 13.5	M20x1.5	22,5	27	-
32-160/2.2 (M)	50	95	125	165	16	4	-	32	75	100	140	14	1	292	132	160	124	141	80	70	118	190	240	254	408	432	-	219+230	244+255	-	PG 13.5	M20x1.5	27,7	28	-
32-200/3.0	50	95	125	165	16	4	-	32	75	100	140	14	1	340	160	180	124	-	80	70	119	190	240	296	-	471	-	-	244+255	-	PG 13.5	-	-	35,1	-
32-200/4.0	50	95	125	165	16	4	-	32	75	100	140	14	1	340	160	180	141	-	80	70	119	190	240	296	-	494	-	-	253	-	PG 16	-	-	38,2	-
32-200/5.5	50	95	125	165	16	4	-	32	75	100	140	14	1	340	160	180	150	-	80	70	119	190	240	296	-	519	-	-	275	PG 13.5	PG 16	-	-	52,2	-
32-200/7.5	50	95	125	165	16	4	-	32	75	100	140	14	1	340	160	180	150	-	80	70	119	190	240	296	-	519	539	-	275	PG 13.5	PG 16	-	-	60,1	-
40-125/1.5 (M)	65	115	145	185	16	4	-	40	80	110	150	14	1	252	112	140	124	141	80	70	114	160	210	213	408	407	-	219+230	219+230	-	PG 13.5	M20x1.5	20,1	24,6	-
40-125/2.2 (M)	65	115	145	185	16	4	-	40	80	110	150	14	1	252	112	140	124	141	80	70	114	160	210	213	408	432	-	219+230	244+255	-	PG 13.5	M20x1.5	25,8	26,1	-
40-160/3.0	65	115	145	185	16	4	-	40	80	110	150	14	1	292	132	160	124	-	80	70	118	190	240	254	-	471	-	-	244+255	-	PG 13.5	-	-	26,6	-
40-160/4.0	65	115	145	185	16	4	-	40	80	110	150	14	1	292	132	160	141	-	80	70	118	190	240	254	-	494	-	-	253	-	PG 16	-	-	40,8	-
40-200/5.5	65	115	145	185	16	4	-	40	80	110	150	14	2	340	160	180	150	-	100	70	115	212	265	296	-	539	-	-	275	PG 13.5	PG 16	-	-	52,5	-
40-200/7.5	65	115	145	185	16	4	-	40	80	110	150	14	2	340	160	180	150	-	100	70	115	212	265	296	-	539	559	-	275	PG 13.5	PG 16	-	-	59,3	-
40-200/11	65	115	145	185	16	4	-	40	80	110	150	14	2	360	160	180	178	-	100	70	115	212	265	296	-	595	595	-	359	PG 13.5	PG 21	-	-	69,6	-
50-125/2.2 (M)	65	115	145	185	16	4	-	50	95	125	165	16	2	292	132	160	124	141	100	70	114	190	240	254	428	452	-	219+230	244+255	-	PG 13.5	M20x1.5	29,4	32	-
50-125/3.0	65	115	145	185	16	4	-	50	95	125	165	16	2	292	132	160	124	-	100	70	114	190	240	254	-	491	-	-	244+255	-	PG 13.5	-	-	30,9	-
50-125/4.0	65	115	145	185	16	4	-	50	95	125	165	16	2	292	132	160	141	-	100	70	114	190	240	254	-	514	-	-	253	-	PG 16	-	-	40,9	-
50-160/5.5	65	115	145	185	16	4	-	50	95	125	165	16	2	340	160	180	150	-	100	70	115	212	265	296	-	539	-	-	275	PG 13.5	PG 16	-	-	46,5	-
50-160/7.5	65	115	145	185	16	4	-	50	95	125	165	16	2	340	160	180	150	-	100	70	115	212	265	296	-	539	559	-	275	PG 13.5	PG 16	-	-	58,6	-
50-200/9.2	65	115	145	185	16	4	-	50	95	125	165	16	2	360	160	200	178	-	100	70	115	212	265	296	-	595	595	-	359	PG 13.5	PG 21	-	-	63,9	-
50-200/11	65	115	145	185	16	4	-	50	95	125	165	16	2	360	160	200	178	-	100	70	115	212	265	296	-	595	595	-	359	PG 13.5	PG 21	-	-	69,6	-
65-125/4	80	134	160	200	18	8	4	65	115	145	185	16	2	340	160	180	141	-	100	95	140	212	280	254	-	514	-	-	253	-	PG 16	-	-	37,7	-
65-125/5.5	80	134	160	200	18	8	4	65	115	145	185	16	2	340	160	180	150	-	100	95	140	212	280	254	-	539	-	-	275	PG 13.5	PG 16	-	-	48,7	-
65-125/7.5	80	134	160	200	18	8	4	65	115	145	185	16	2	340	160	180	150	-	100	95	140	212	280	254	-	539	559	-	275	PG 13.5	PG 16	-	-	52,1	-
65-160/7.5	80	134	160	200	18	8	4	65	115	145	185	16	2	360	160	200	150	-	100	95	140	212	280	296	-	539	559	-	275	PG 13.5	PG 16	-	-	55,3	-
65-160/9.2	80	134	160	200	18	8	4	65	115	145	185	16	2	360	160	200	178	-	100	95	140	212	280	296	-	595	595	-	359	PG 13.5	PG 21	-	-	61	-
65-160/11	80	134	160	200	18	8	4	65	115	145	185	16	2	360	160	200	178	-	100	95	140	212	280	296	-	595	595	-	359	PG 13.5	PG 21	-	-	67,4	-

(*) Only for IE3 Motors [1] Standard [2] On request [1~] Only for single phase [3~] Only for three phase

PUMP 3(.)M 50-200, 65-160/15, 65-200

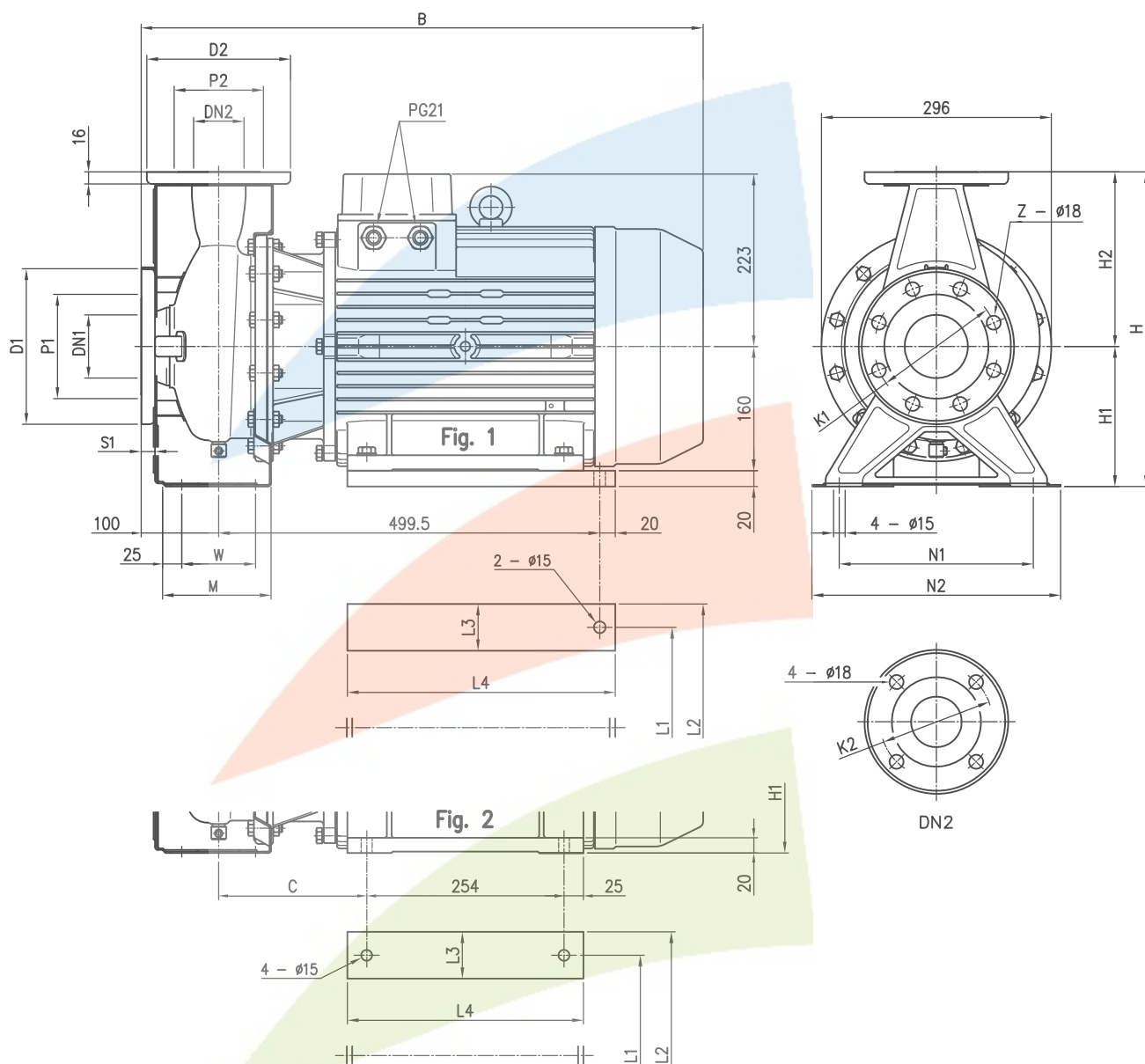

Model	Dimensions [mm]																				Weight [kgf]					
	∅ DN1	∅ P1	∅ K1	∅ D1	S1	Z [1]	Z [2]	∅ DN2	∅ P2	∅ K2	∅ D2	Fig.	H	H1	H2	W	M	N1	N2	B		C	L1	L2	L3	L4
50-200/15	65	115	145	185	16	4	-	50	95	125	165	2	360	160	200	70	115	212	265	723	190.5	254	318	65	304	105,1
65-160/15	80	134	160	200	18	8	4	65	115	145	185	2	360	160	200	95	140	212	280	732	199.5	254	318	65	304	107,1
65-200/15	80	134	160	200	18	8	4	65	115	145	185	1	405	180	225	95	140	250	320	732	-	254	314	60	345	110,1
65-200/18.5	80	134	160	200	18	8	4	65	115	145	185	1	405	180	225	95	140	250	320	732	-	254	314	60	345	125,3
65-200/22	80	134	160	200	18	8	4	65	115	145	185	1	405	180	225	95	140	250	320	732	-	254	314	60	345	136,1

[1] Standard [2] On request

PUMP 3LMZ 32, 40, 50-125/160/200/9.2/11, 65-125/160/7.5/9.2/11

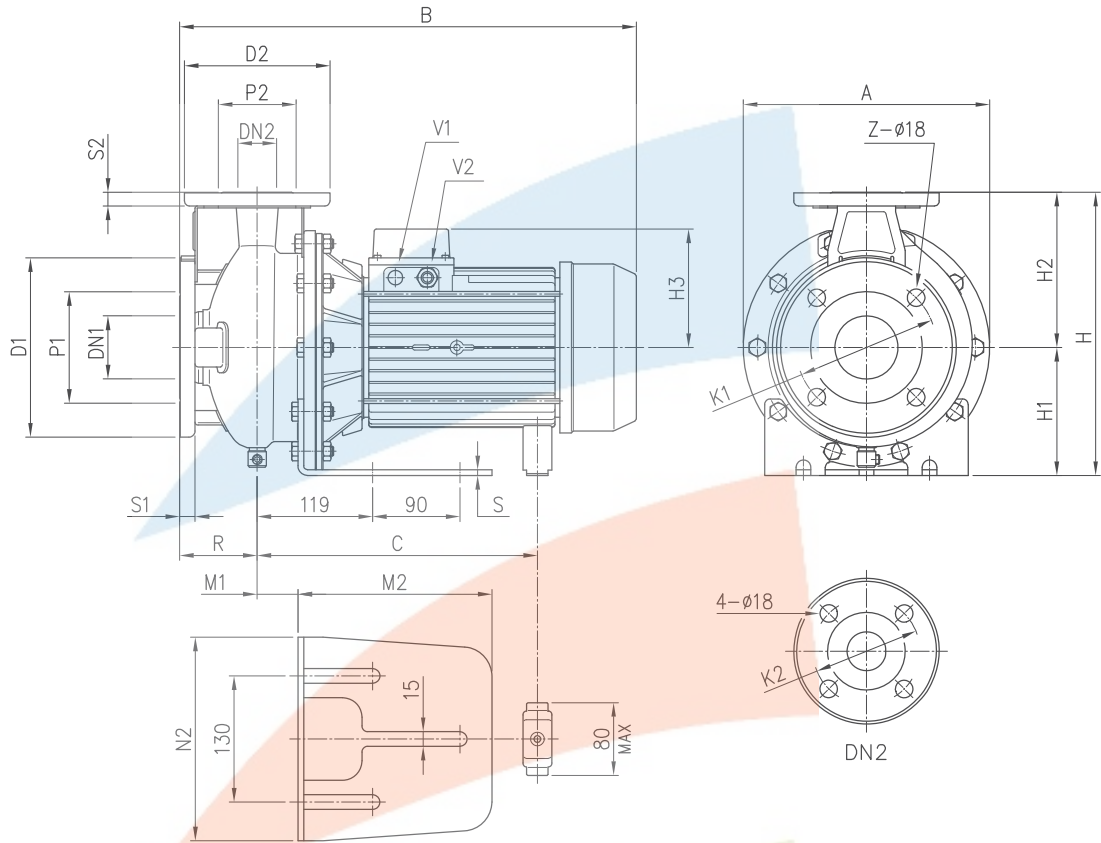

Model	Dimensions (mm)																							Weight [kgf]				
	∅ DN1	∅ P1	∅ K1	∅ D1	S1	Z	∅ DN2	∅ P2	∅ K2	∅ D2	S2	H	H1	H2	H3	R	M1	M2	S	N2	A	B (*)	C	V1	V2	Weight [kgf]	(*)	
32-125/1.1	50	95	125	165	16	4	32	75	100	140	14	252	112	140	124	80	32,5	212	6	190	213	407	-	-	-	PG 13.5	24,1	-
32-160/1.5	50	95	125	165	16	4	32	75	100	140	14	292	132	160	124	80	42	200	6	210	254	407	-	-	-	PG 13.5	27	-
32-160/2.2	50	95	125	165	16	4	32	75	100	140	14	292	132	160	124	80	42	200	6	210	254	432	-	-	-	PG 13.5	28	-
32-200/3.0	50	95	125	165	16	4	32	75	100	140	14	340	160	180	124	80	39	205	8	220	296	471	-	-	-	PG 13.5	35,1	-
32-200/4.0	50	95	125	165	16	4	32	75	100	140	14	340	160	180	141	80	39	205	8	220	296	494	-	-	-	PG 16	38,2	-
32-200/5.5	50	95	125	165	16	4	32	75	100	140	14	340	160	180	150	80	39	205	8	220	296	519	-	-	PG 13.5	PG 16	52,2	-
32-200/7.5	50	95	125	165	16	4	32	75	100	140	14	340	160	180	150	80	39	205	8	220	296	519	539	275	PG 13.5	PG 16	-	60,1
40-125/1.5	65	115	145	185	16	4	40	80	110	150	14	252	112	140	124	80	32,5	212	6	190	213	407	-	-	-	PG 13.5	24,6	-
40-125/2.2	65	115	145	185	16	4	40	80	110	150	14	252	112	140	124	80	32,5	212	6	190	213	432	-	-	-	PG 13.5	26,1	-
40-160/3.0	65	115	145	185	16	4	40	80	110	150	14	292	132	160	124	80	42	200	6	210	254	471	-	-	-	PG 13.5	26,6	-
40-160/4.0	65	115	145	185	16	4	40	80	110	150	14	292	132	160	141	80	42	200	6	210	254	494	-	-	-	PG 16	40,8	-
40-200/5.5	65	115	145	185	16	4	40	80	110	150	14	340	160	180	150	100	39	205	8	220	296	539	-	-	PG 13.5	PG 16	52,5	-
40-200/7.5	65	115	145	185	16	4	40	80	110	150	14	340	160	180	150	100	39	205	8	220	296	539	559	275	PG 13.5	PG 16	-	59,3
40-200/11	65	115	145	185	16	4	40	80	110	150	14	340	160	180	178	100	39	205	8	220	296	595	-	359	PG 13.5	PG 21	-	69,6
50-125/2.2	65	115	145	185	16	4	50	95	125	165	16	292	132	160	124	100	42	200	6	210	254	452	-	-	-	PG 13.5	32	-
50-125/3.0	65	115	145	185	16	4	50	95	125	165	16	292	132	160	124	100	42	200	6	210	254	491	-	-	-	PG 13.5	30,9	-
50-125/4.0	65	115	145	185	16	4	50	95	125	165	16	292	132	160	141	100	42	200	6	210	254	514	-	-	-	PG 16	40,9	-
50-160/5.5	65	115	145	185	16	4	50	95	125	165	16	340	160	180	150	100	39	205	8	220	296	539	-	-	PG 13.5	PG 16	46,5	-
50-160/7.5	65	115	145	185	16	4	50	95	125	165	16	340	160	180	150	100	39	205	8	220	296	539	559	275	PG 13.5	PG 16	-	58,6
50-200/9.2	65	115	145	185	16	4	50	95	125	165	16	360	160	200	178	100	39	205	8	220	296	595	-	359	PG 13.5	PG 21	-	63,9
50-200/11	65	115	145	185	16	4	50	95	125	165	16	360	160	200	178	100	39	205	8	220	296	595	-	359	PG 13.5	PG 21	-	69,6
65-125/4	80	134	160	200	18	8	65	115	145	185	16	340	160	180	141	100	42	200	6	210	254	514	-	-	-	PG 16	37,7	-
65-125/5.5	80	134	160	200	18	8	65	115	145	185	16	340	160	180	150	100	42	200	6	210	254	539	-	-	PG 13.5	PG 16	48,7	-
65-125/7.5	80	134	160	200	18	8	65	115	145	185	16	340	160	180	150	100	42	200	6	210	254	539	559	275	PG 13.5	PG 16	-	52,1
65-160/7.5	80	134	160	200	18	8	65	115	145	185	16	360	160	200	150	100	39	205	8	220	296	539	559	275	PG 13.5	PG 16	-	55,3
65-160/9.2	80	134	160	200	18	8	65	115	145	185	16	360	160	200	178	100	39	205	8	220	296	595	-	359	PG 13.5	PG 21	-	61
65-160/11	80	134	160	200	18	8	65	115	145	185	16	360	160	200	178	100	39	205	8	220	296	595	-	359	PG 13.5	PG 21	-	67,4

(*) Only for IE3 Motors

PUMP 3LMZ 50-200/15, 65-160/15, 65-200

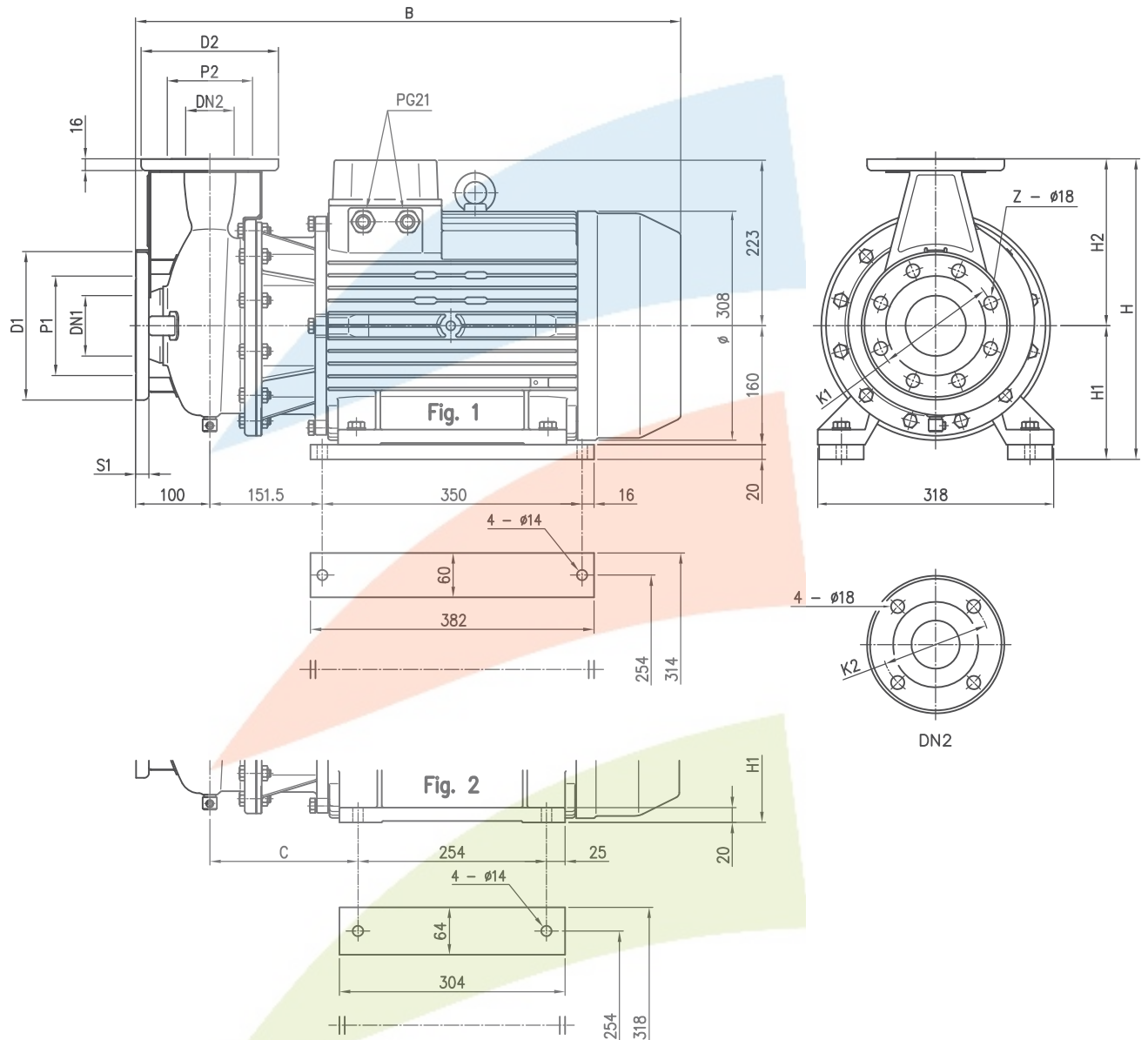

Model	Dimensions [mm]																Weight [kgf]
	Ø DN1	Ø P1	Ø K1	Ø D1	S1	Z	Ø DN2	Ø P2	Ø K2	Ø D2	Fig.	H	H1	H2	B	C	
50-200/15	65	115	145	185	16	4	50	95	125	165	2	360	160	200	723	190,5	105,1
65-160/15	80	134	160	200	18	8	65	115	145	185	2	360	160	200	732	199,5	107,1
65-200/15	80	134	160	200	18	8	65	115	145	185	1	405	180	225	732	-	110,1
65-200/18.5	80	134	160	200	18	8	65	115	145	185	1	405	180	225	732	-	125,3
65-200/22	80	134	160	200	18	8	65	115	145	185	1	405	180	225	732	-	136,1

PUMP 3LM 80-160/11

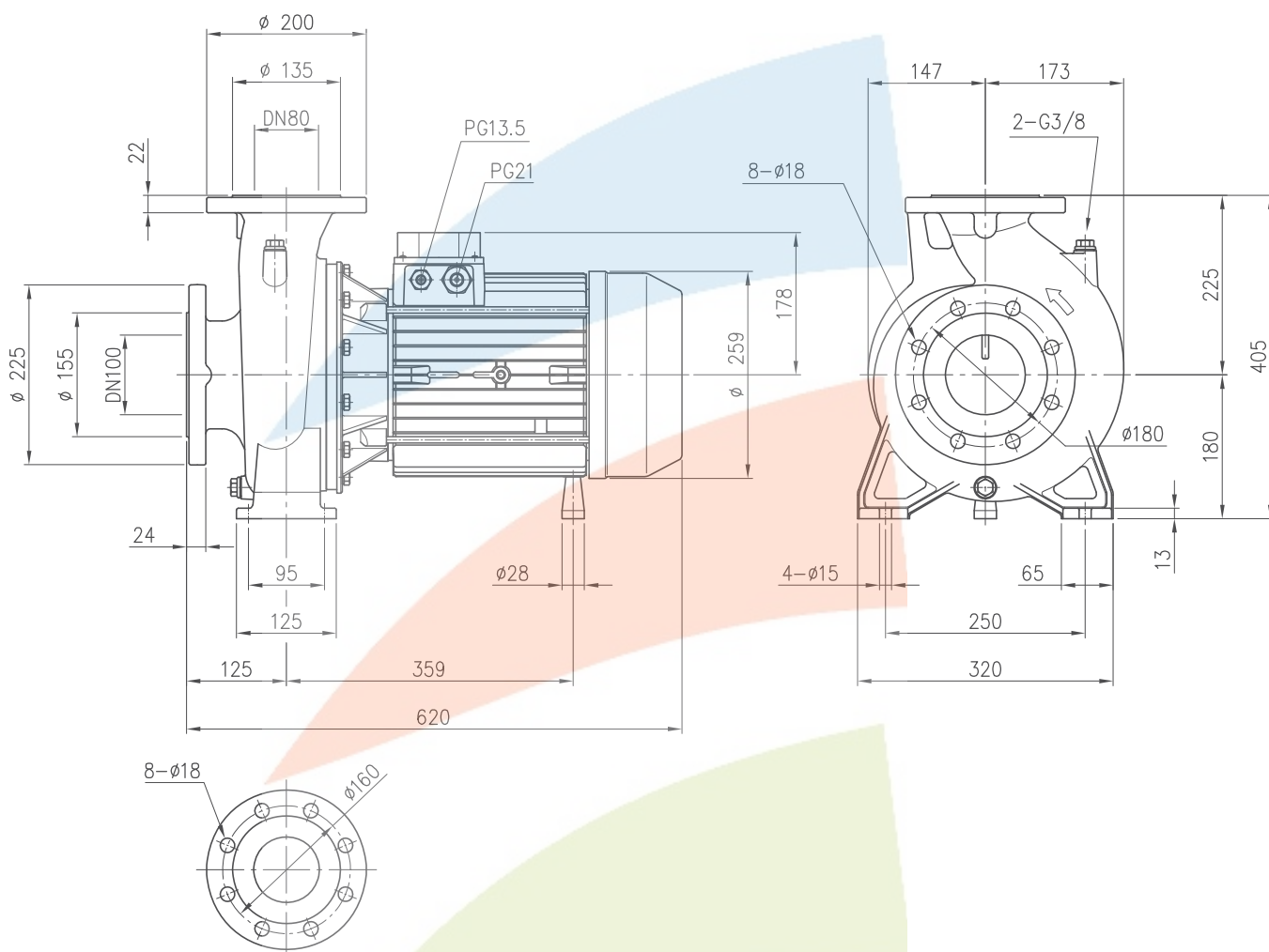

Weight: 100 kgf

PUMP 3LM 80-160/15R/15/18.5

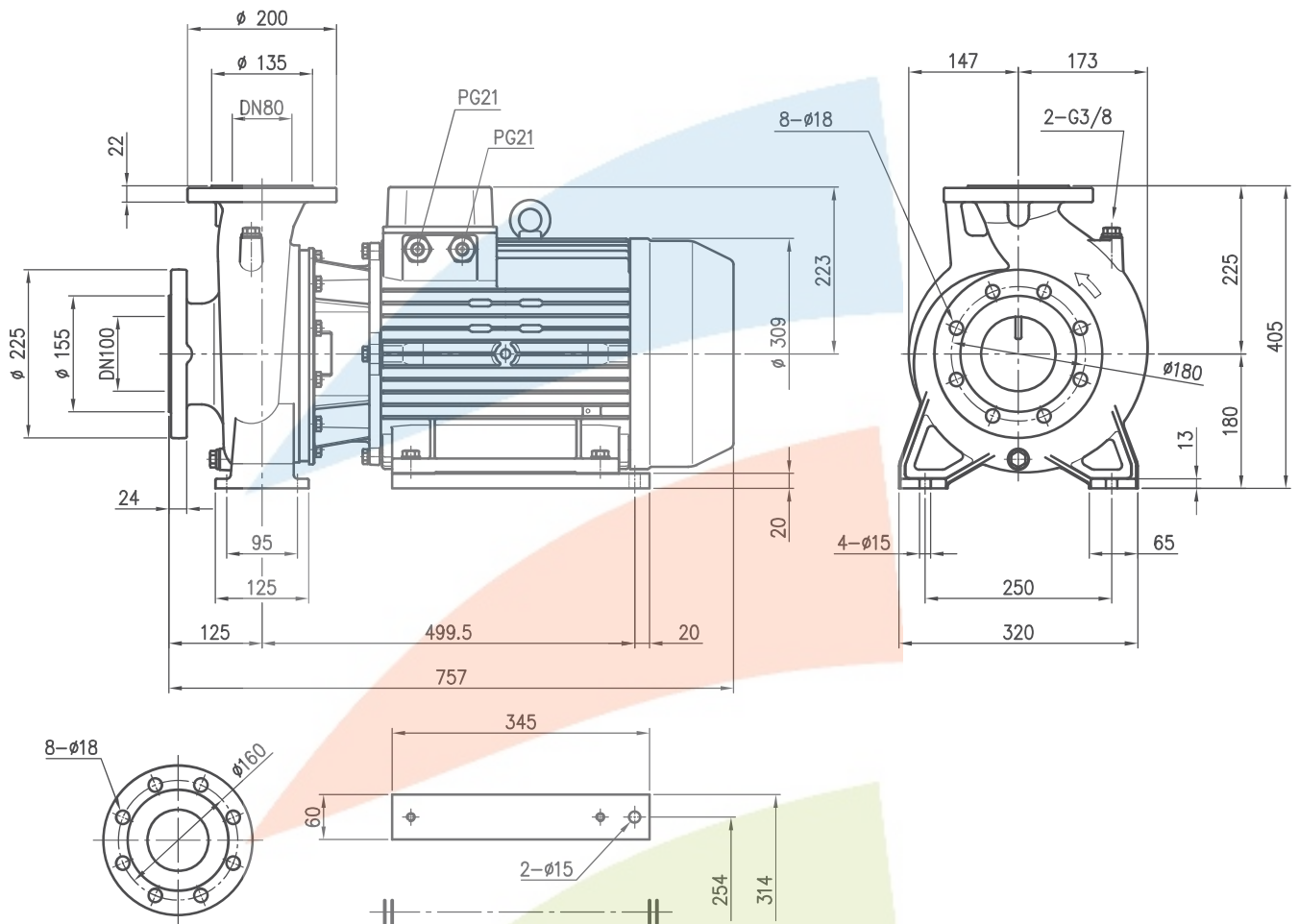

Weight:
 80-160/15R : 130.1 kgf
 80-160/15 : 131.1 kgf
 80-160/18.5 : 145.3 kgf