

# BLAGDON

## B25 & X25

### AIR OPERATED DOUBLE DIAPHRAGM PUMP

#### 1" Non-Metallic 05 Series

B25

DIMENSIONS

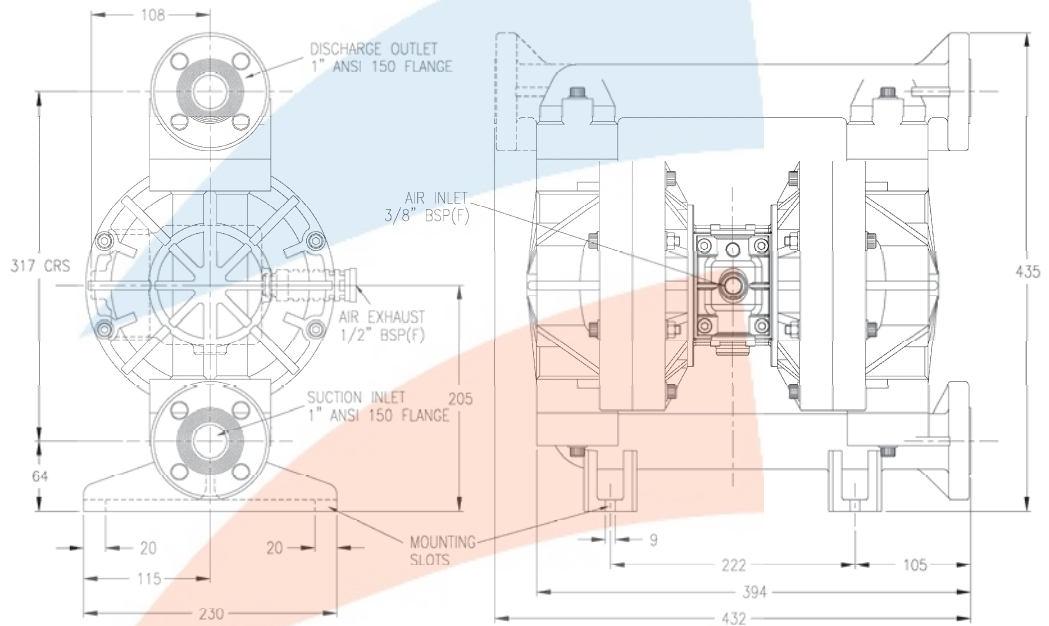

General Assembly :- B2505 Moulded Pump, all dimensions +/- 3mm

B25

PERFORMANCE

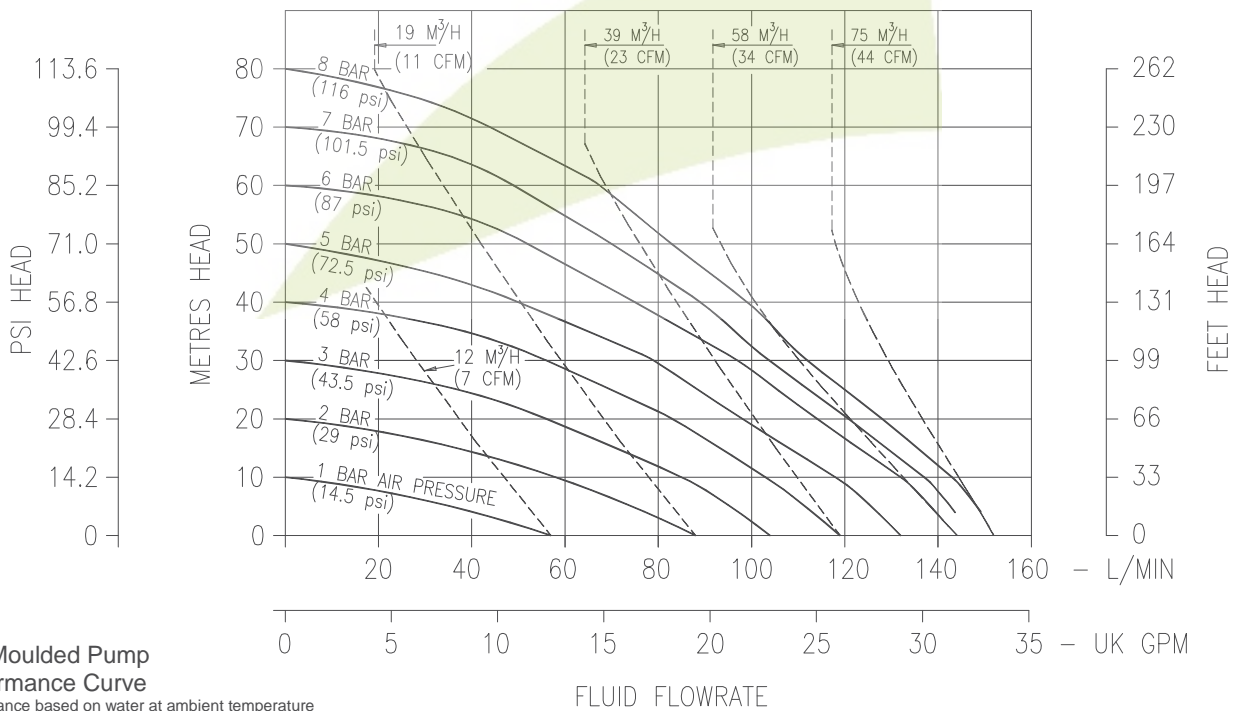

B25 Moulded Pump Performance Curve  
Performance based on water at ambient temperature

<b>FLUID CONNECTIONS</b> 1" ANSI 150 / DN25 Compatible Flange	<b>CAPACITY</b> 0 - 152 Liters/Minute (0 - 33 Gallons/Minute)	<b>MAX SOLIDS</b> 3 MM (1/8")	<b>MAX DISCHARGE HEAD</b> 88 Meters (289 ft)	<b>DISPLACEMENT/STROKE</b> 0.475 Litres (0.1 UK Gallons)
<b>MAX. WORKING PRESSURE</b> 8.6 Bar (125 psi)	<b>AIR INLET</b> 3/8" BSP (F)	<b>TEMPERATURE LIMITS</b> Polypropylene :- 70°C PVDF (Kynar) :- 90°C		<b>PUMP WEIGHTS :-</b> PT/GT :- 13.3 Kg PW/GW :- 15 Kg KT :- 20 Kg KW :- 21.7 Kg

**ⓘ Caution - Operating temperature limitations are as follows:**

Materials	Operating Temperatures		
	Maximum	Minimum	Optimum
<b>Buna-n</b> - General purpose, oil resistant. Shows good solvent, oil, water and hydraulic fluid resistance. Should not be used with highly polar solvents like acetone and MEK, ozone, chlorinated hydrocarbons and nitro hydrocarbons.	176°F 80°C	-18°F -28°C	50° to 140°F 10° to 60°C
<b>EPDM</b> - Shows very good water and chemical resistance. Has poor resistance to oils and solvents, but is fair on ketones and alcohols.	212°F 100°C	-11°F -24°C	50° to 212°F 10° to 100°C
<b>Neoprene</b> - All purpose. Resistant to vegetable oil. Generally not affected by moderate chemicals, fats greases and many oils and solvents. Generally attacked by strong oxidising acids, ketones, esters, nitro hydro carbons and chlorinated aromatic hydrocarbons.	212°F 100°C	-4°F -20°C	50° to 130°F 10° to 54°C
<b>Santoprene®</b> - Injection moulded thermoplastic elastomer with no fabric layer. Long mechanical flex life. Excellent abrasion resistance.	212°F 100°C	-10°F -23°C	50° to 212°F 10° to 100°C
<b>PTFE</b> - Chemically inert, virtually impervious. Very few chemicals are known to react chemically with PTFE : molten alkali metals, turbulent liquid or gaseous fluorine and a few fluoro-chemicals such as chlorine trifluoride or oxygen difluoride which readily liberate free fluorine at elevated temperatures.	356°F 180°C	32°F 0°C	50° to 212°F 10° to 100°C
<b>Viton®</b> - Shows good resistance to a wide range of oils and solvents : especially all aliphatic, aromatic and halogenated hydrocarbons, acids, animal and vegetable oils.	356°F 180°C	0°F -18°C	75° to 212°F 24° to 100°C
<b>Polypropylene</b> - High strength, light weight, corrosion resistant polyolefin which easily withstands most chemicals, with no known solvent at room temperature.	158°F 70°C	-40°F -40°C	50° to 140°F 10° to 60°C

TYPICAL CODE = B25.05.P T. B B. T T P - T

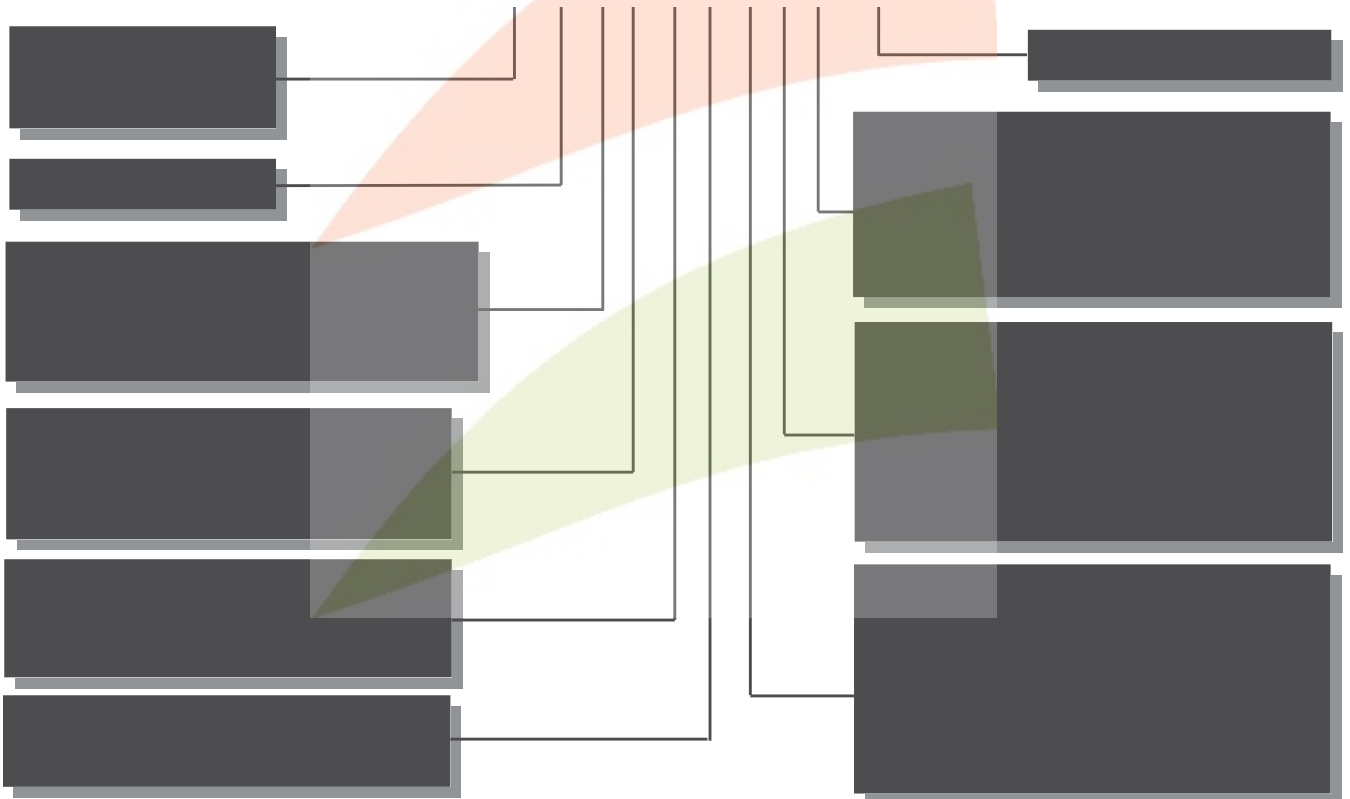

**IMPORTANT**

This pump should be used in accordance with the requirements of the Safety, Health & Welfare at Work Act 2005. All business conducted subject to IDEX Pump Technologies, Ireland. Terms and Conditions of Sale, available on request.



IDEX Pump Technologies (Ireland) Ltd.,  
A Unit of IDEX Corporation,  
R79, Shannon, Co Clare, IRELAND.  
TEL. : +353 61 471933 FAX. : +353 61 475046  
Web Site : www.blagdonpump.com  
E-Mail : sales@blagdonpump.com