



BLAGDON

B15

AIR OPERATED DOUBLE DIAPHRAGM PUMP

Stainless Steel

B15

DIMENSIONS

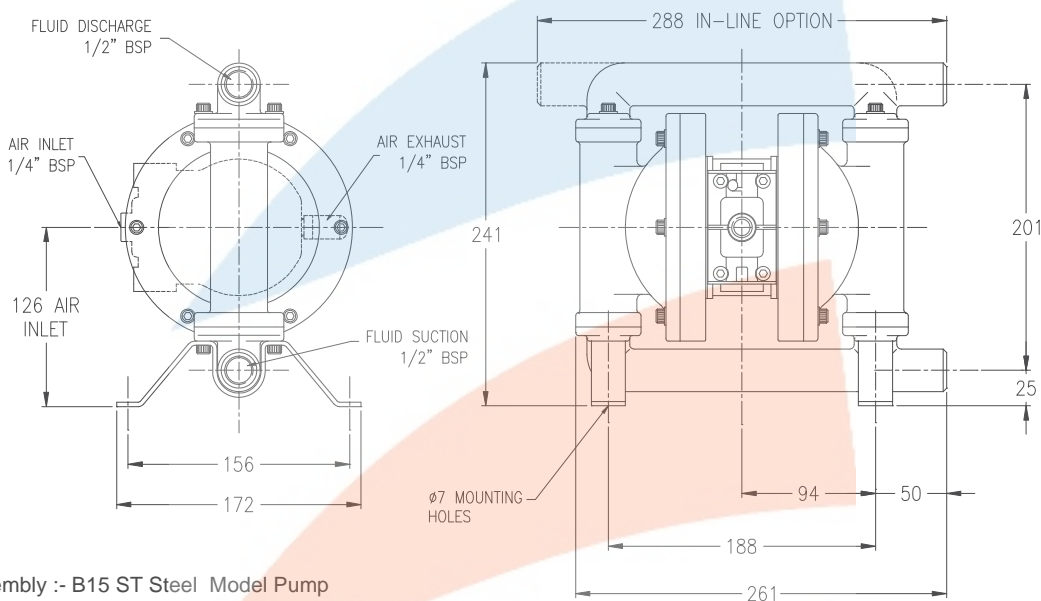

General Assembly :- B15 ST Steel Model Pump
All dimensions +/- 2mm

B15

PERFORMANCE

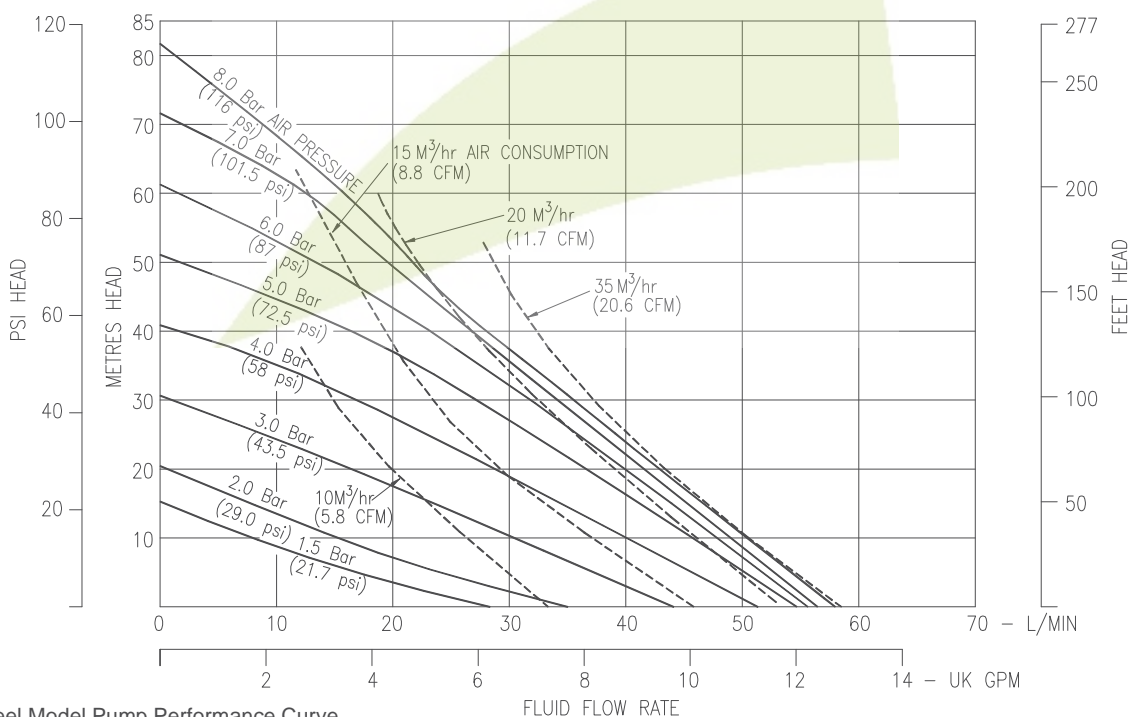

B15 ST Steel Model Pump Performance Curve
Performance based on water at ambient temperature

FLUID CONNECTIONS 1/2" BSP(F)	CAPACITY 0 - 58 Litres/Minute (0 - 12.7 Gallons/Minute)	MAX SOLIDS 2 MM (5/64")	MAX DISCHARGE HEAD 88 Meters (289 ft)	DISPLACEMENT/STROKE 0.075 Litres (0.02 UK Gallons)
MAX. WORKING PRESSURE 8.6 Bar (125 psi)	AIR INLET 1/4" BSP (F)	TEMPERATURE LIMITS Determined by Elastomers		PUMP WEIGHTS :- SA :- 8.7 Kg SS :- 12.2 Kg

ⓘ Caution - Operating temperature limitations are as follows:

Operating Temperatures

Materials	Operating Temperatures		
	Maximum	Minimum	Optimum
Buna-n - General purpose, oil resistant. Shows good solvent, oil, water and hydraulic fluid resistance. Should not be used with highly polar solvents like acetone and MEK, ozone, chlorinated hydrocarbons and nitro hydrocarbons.	176°F 80°C	-18°F -28°C	50° to 140°F 10° to 60°C
EPDM - Shows very good water and chemical resistance. Has poor resistance to oils and solvents, but is fair on ketones and alcohols.	212°F 100°C	-11°F -24°C	50° to 212°F 10° to 100°C
Neoprene - All purpose. Resistant to vegetable oil. Generally not affected by moderate chemicals, fats greases and many oils and solvents. Generally attacked by strong oxidising acids, ketones, esters, nitro hydro carbons and chlorinated aromatic hydrocarbons.	212°F 100°C	-4°F -20°C	50° to 130°F 10° to 54°C
Santoprene® - Injection moulded thermoplastic elastomer with no fabric layer. Long mechanical flex life. Excellent abrasion resistance.	212°F 100°C	-10°F -23°C	50° to 212°F 10° to 100°C
PTFE - Chemically inert, virtually impervious. Very few chemicals are known to react chemically with PTFE : molten alkali metals, turbulent liquid or gaseous fluorine and a few fluoro-chemicals such as chlorine trifluoride or oxygen difluoride which readily liberate free fluorine at elevated temperatures.	356°F 180°C	32°F 0°C	50° to 212°F 10° to 100°C
Viton® - Shows good resistance to a wide range of oils and solvents : especially all aliphatic, aromatic and halogenated hydrocarbons, acids, animal and vegetable oils.	356°F 180°C	0°F -18°C	75° to 212°F 24° to 100°C

TYPICAL CODE = B15.01.S A. B B. E T S - L F

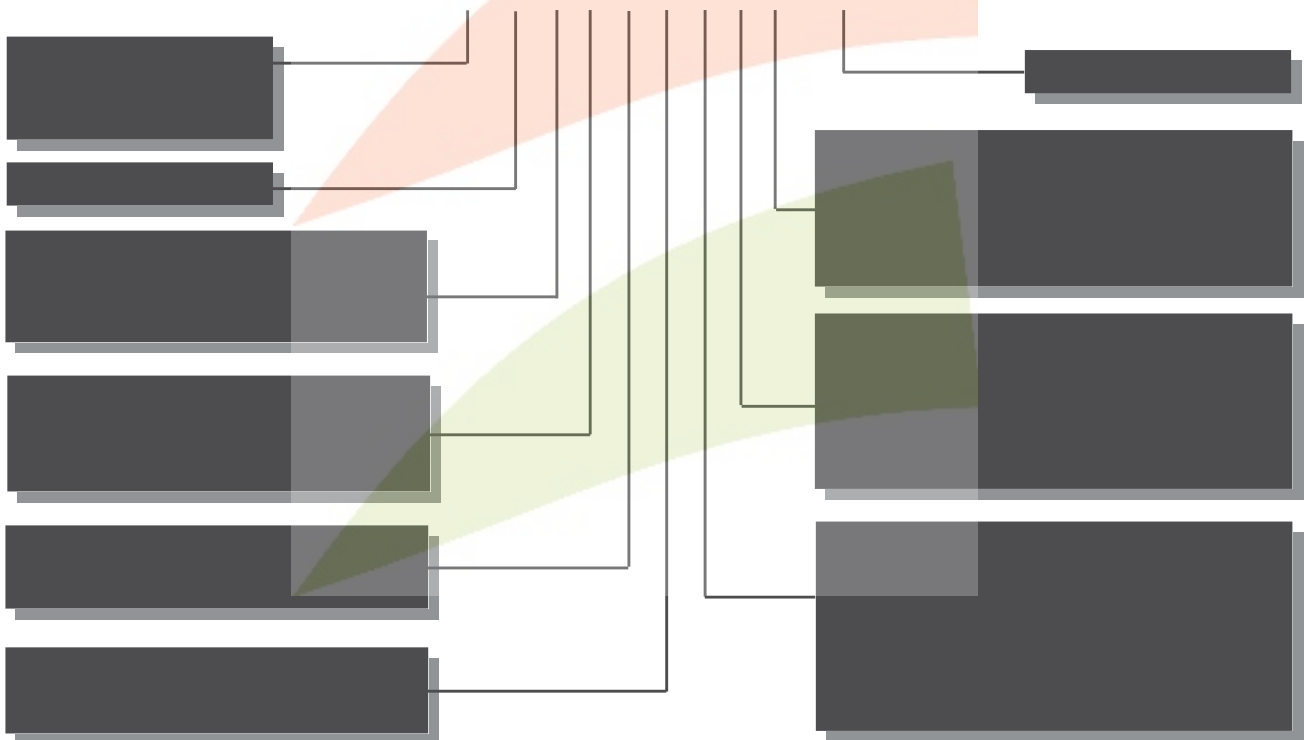

IMPORTANT

This pump should be used in accordance with the requirements of the Safety, Health & Welfare at Work Act 2005. All business conducted subject to IDEX Pump Technologies, Ireland. Terms and Conditions of Sale, available on request.



**BLAGDON
PUMP**

IDEX Pump Technologies (Ireland) Ltd.,
A Unit of IDEX Corporation,
R79, Shannon, Co Clare, IRELAND.
TEL : +353 61 471933 FAX : +353 61 475046
Web Site : www.blagdonpump.com
E-Mail : sales@blagdonpump.com