

# ABRAZADERA REFORZADA M8+M10 - A-2

REINFORCED PIPE CLAMP M8 + M10 - A-2

## FICHA TÉCNICA

TECHNICAL DATA SHEET

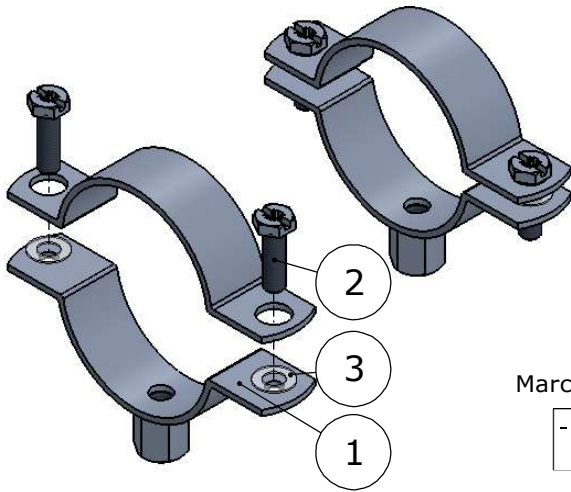

Marca (ejemplo)

- A - 304  
Ø 54

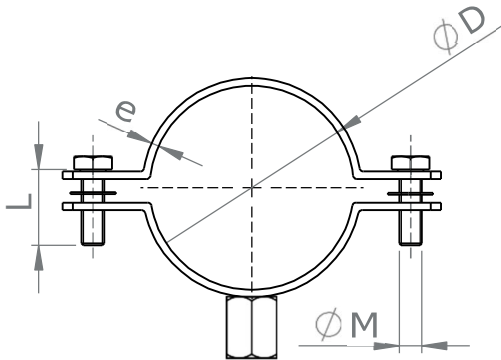
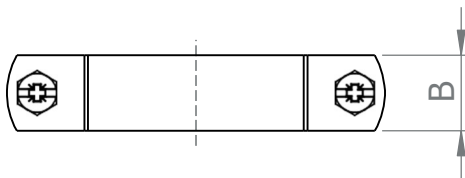

Detalle Tuerca M8+M10  
Escala 1:1

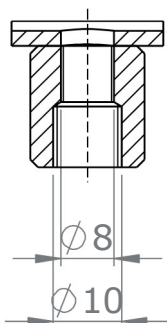

3	Arandela	Washer	-	-
2	Tornillo	Screw	A2-70	-
1	Banda	Band	AISI 304	Pulido
Nº	Pieza	Part	Material	Recubrimiento

Medida/Size			Tornillo	Banda
"	ØD(mm)	Apertura	MxL (mm)	Bxe (mm)
3/8	18	16-20	M6x16	20x2
1/2	22	20-25		
3/4	28	26-31		
1"	35	31-36		
1 1/4	40	38-44	M6x20	
1 1/2	48	45-51		
	54	52-57		
2"	60	57-63		
	70	69-73		
2 1/2	75	73-77		
	84	83-86	M6x25	
3"	90	87-94		
	104	103-110		
4"	110	107-114		
4"	115	110-118		
5"	125	123-131		
	133	131-135		
5"	140	136-145		
	150	147-155		
	154	153-159		
6"	160	158-164	M6x30	
	180	178-184		
	204	200-206		
	220	216-226		
	225	223-227		
	250	249-256		
	280	279-285		
	300	300-307		
	315	314-321		
	350	350-359		
	400	398-408		
	500	499-505		

Dibujo Técnico (Título):

Abrazadera Reforzada M8+M10 en W4

Tolerancia: ±0,5

Tolerancias Dimensionales Generales DIN ISO 2768- m  
Tolerancias Geométricas Generales DIN ISO 2768- K  
Tolerancias ISO 8015

A4

Escala: 1:2

Hoja 1 de 1